

SFP-10GB-MM**Features**

- Duplex LC Connector
- Support hot-pluggable
- Metal with lower EMI
- Excellent ESD protection
- VCSEL Transmitter and PIN Receiver
- Typical Center Wavelength: 850nm
- Max link length up to 300m on MMF
- RoHS Compliant and Lead-Free
- Digital diagnostic compatible with SFF-8472
- Case Operation Temperature: -5°C~+70°C
- Single 3.3V power supply and Low power dissipation

Applications

- 10GBASE-SR/SW 10G Ethernet
- 1200-M5-SN-I,1200-M E-SN-I,1200-M6-SN-I 10G Fibre Channel

Description

SFP-10GB-MM is specifically designed for the high performance integrated duplex data transmission over multi mode optical fiber.

This transceiver module is compliant with the Small Form-factor Pluggable Plus (SFP+) Multisource Agreement (SFF-8431 Rev4.1).This transceiver type is specifically optimized for transport of serial data at up to 10.3125 Gbps, with link characteristics complied with 10-Gigabit Ethernet 10GBASE-SR/SW base IEEE 802.3ae and 10G Fibre Channel 1200-SM-LL-L. 5

Absolute Maximum Ratings

Parameter	Symbol	Min.	Typ.	Max.	Unit	Notes
Maximum Supply Voltage	Vcc3	-0.5	-	4.0	V	
Storage Temperature	TS	-40	-	85	°C	
Operating Humidity	-	5	-	95	%	
Maximum Supply Voltage	Vcc3	-0.5	-	4.0	V	

Recommended Operating Conditions

Parameter	Symbol	Min.	Typ.	Max.	Unit	Notes
Power Supply Voltage	V _{cc}	3.13	3.30	3.47	V	
Power Supply Current	I _{cc}	-	-	300	mA	
Case Operating Temperature	T _{op}	-5	-	70	°C	
Data Rate	-	-	10.3125	-	Gb/s	
9/125um G652 SMF	L _{max}	-	-	300	m	
Baud Rate Tolerance		-100		+100	ppm	

Performance Specifications - Transmitter

(-5°C<T_c<+70°C; +2.97V<V_{cc}<+3.63V)

Parameter	Symbol	Min.	Typ.	Max.	Unit	Notes	
Input Differential Impedance	Z _{in}	90	100	110	Ω		
Tx_Fault	Normal Operation	VOL	-0.3	-	0.4	V	
	Transmitter Fault	VOH	2.4	-	V _{cc}	V	
TX_Disable (Note 1)	Disable	V _{IH}	2.0	-	V _{cc} +0.3	V	
	Enable	V _{IL}	-0.3	-	0.8	V	
Average Launch Optical Power	P _{out}	-7.3	-	-1.0	dBm		
Extinction Ratio	ER	3.0		-	dB		
Transmitter and Dispersion Penalty	TDP	-	-	3.9	dB		
Average Launch power of OFF TX	P _{off}	-	-	-30	dBm		
Optical Wavelength	λ	840		860	nm		
RMS Spectral width (max)	Δλ	Refer to Table 52-8 of IEEE					
Optical Modulation Amplitude	OMA	802.3-2005.					
Relative Intensity Noise(OMA)	RIN ₁₂			-128	dB/Hz		
Optical Return Loss Tolerance	ORLT			12	dB		
Eye Diagram	Compatible with IEEE 802.3-2005						

Performance Specifications - Receiver

(-5C<Tc<+70°C; +2.97V<Vcc<+3.6V)

Parameter	Symbol	Min.	Typ.	Max.	Unit	Notes
Differential Data Output Swing	Vout	300	-	800	mV	
Output Differential Impedance	Zin	90	100	110	Ω	
Receiver sensitivity (max) in OMA	PIN-SENS(OMA)	-	-	-11.1	dBm	BER<10E-12; PRBS2^31
Receiver Sensitivity	PIN-SENS	-	-	-9.9	dBm	
Overload		-1.0	-	-	dBm	
Receiver reflectance	-	-	-	-12	dB	
Optical Center Wavelength	λC	840	-	860	nm	
Los Assert		-32	-	-	dBm	
Los De-assert		-	-	-15	dBm	
Los hysteresis		0.5	-	-	dB	

SFP Transceiver Electrical Pad Layout

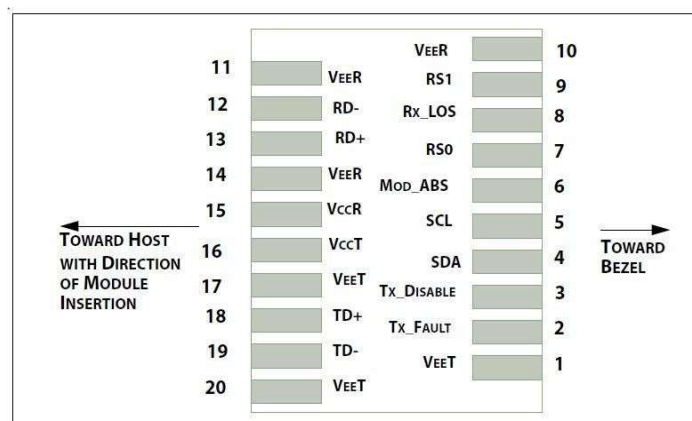

Pin Function Definitions

Pin Num	Name	Function	Plug Seq.	Notes
1	VeeT	Module Transmitter Ground	1	
2	Tx_FAULT	Module Transmitter Fault	3	Note 1
3	Tx_DISAB	Transmitter Disable; Turns off	3	Note 2, Module

	LE	transmitter laser output		disables on high or open
4	SDA	2-wire Serial Interface Data Line (Same as MOD-DEF2 in INF-8074i)	3	
5	SCL	2-wire Serial Interface Clock (Same as MOD-DEF1 in INF-8074i)	3	
6	MOD-ABS	Module Absent, connected to VeeT or VeeR in the module	3	
7	RS0	Rate Select 0, optionally controls SFP+ module receiver.	3	Note 3
8	Rx_LOS	Receiver Loss of Signal Indication (In FC designated as Rx_LOS, in SONET designated as LOS and in Ethernet designated as Signal Detect)	3	Note 4
9	RS1	Rate Select 1, optionally controls SFP+ module transmitter	1	Note 3
10	VeeR	Module Receiver Ground	1	Note 5
11	VeeR	Module Receiver Ground	1	Note 5
12	RD-	Receiver Inverted Data Output	3	Note 6
13	RD+	Receiver Non-Inverted Data Output	3	Note 6
14	VeeR	Module Receiver Ground	1	Note 5
15	VccR	Module Receiver 3.3 V Supply	2	3.3 ± 10%, Note 7
16	VccT	Module Transmitter 3.3 V Supply	2	3.3 ± 10%, Note 7
17	VeeT	Module Transmitter Ground	1	Note 5
18	TD+	Transmitter Non-Inverted Data Input	3	Note 8
19	TD-	Transmitter Inverted Data Input	3	Note 8
20	VeeT	Module Transmitter Ground	1	Note 5

Notes:

- 1) Tx_Fault is an open collector/drain output, which should be pulled up with a 4.7K – 10KΩ resistor on the host board. Pull up voltage between 2.0V and VccT, R+0.3V. When high, output indicates a laser fault of some kind. Low indicates normal operation. In the low state, the output will be pulled to < 0.8V.
- 2) Tx_disable is an input that is used to shut down the transmitter optical output. It is pulled up within the module with a resistor in the range 4.7 kΩ to 10 kΩ. Its states are:
 Low (0 – 0.8V): Transmitter on
 (>0.8, < 2.0V): Undefined
 High (2.0 – 3.465V): Transmitter Disabled

Open: Transmitter Disabled

- 3) RS0 and RS1 are module inputs and are pulled low to VeeT with > 30 kΩ resistors in the module. RS0 optionally selects the optical receive signaling rate coverage. RS1 optionally selects the optical transmit signaling rate coverage.

These contacts can also be used for AS0 and AS1 if implementing SFF8079. See SFF8079 for details. RS1 is commonly connected to VeeT or VeeR in the classic SFP modules. The host needs to ensure that it will not be damaged if this contact is connected to VeeT or VeeR in the module.

The SFP+ module provides two inputs RS0 and RS1 that can optionally be used for rate selection. RS0 controls the receive path signalling rate capability, and RS1 controls the transmit path signalling rate capability. The host and module may choose to use either, both, or none of these functions. Because contact 9 in the classic SFP INF-8074i is connected to VeeR, an SFP+ host utilizing RS1 must provide short circuit protection.

This rate select functionality can also be controlled by software as defined by SFF-8472. Optionally the rate select methods of Part 2 of SFF-8079 may be used instead of the method described here by setting the management declaration bit (A0h byte 93 bit 2) to 1, see SFF-8472.

<i>Parameter</i>	<i>State</i>	<i>Conditions</i>
RS0	Low	RX signalling rate less than or equal to 4.25 GBd
	High	RX signalling rate greater than 4.25 GBd
RS1	Low	TX signalling rate less than or equal to 4.25 GBd
	High	TX signalling rate greater than 4.25 GBd

- 4) Rx_LOS when high indicates an optical signal level below that specified in the relevant standard. Rx_LOS is an open drain/collector output, but may also be used as an input by supervisory circuitry in the module. For a nominally 3.3 V Vcc_Host using a resistive pull up to Vcc_Host the resistor value shall be in the range 4.7 kΩ to 10 kΩ. For a nominally 2.5 V Vcc_Host using a resistive pull up to Vcc_Host the resistor value shall be in the range 4.7 kΩ to 7.2 kΩ.

The Rx_LOS signal is intended as a preliminary indication to the host in which the module is installed that the received signal strength is below the specified range. Such an indication typically points to non-installed cables, broken ca-bles, or a disabled, failing or a powered off transmitter at the far end of the cable. Additional indications are provided by the host in which the module is installed to verify that the information being transmitted is valid, correctly en-coded, and in the correct format. Such additional indications are outside the scope of the module specification.

Rx_LOS may be an optional function depending on the supported standard. If the Rx_LOS function is not implemented, or is reported via the two-wire inter-face only, the Rx_LOS contact shall be held low by the module and may be con-nected to Vee within

the module.

Rx_LOS assert min and de-assert max are defined in the relevant standard. To avoid spurious transition of Rx_LOS a minimum hysteresis of 0.5 dBo is recommended.

- 5) VeeR and VeeT : The module signal ground contacts, which should be isolated from the module case and which may be internally connected within the SFP module.
- 6) RD-/+: These are the differential receiver outputs. They are AC coupled 100Ω differential lines which should be terminated with 100Ω (differential) at the user SERDES. The AC coupling is done inside the module and is thus not required on the host board.
- 7) VccR and VccT are the receiver and transmitter power supplies. They are defined as 3.3V ±10% at the SFP+ connector pin. Maximum supply current is 300mA. Recommended host board power supply filtering is shown below.

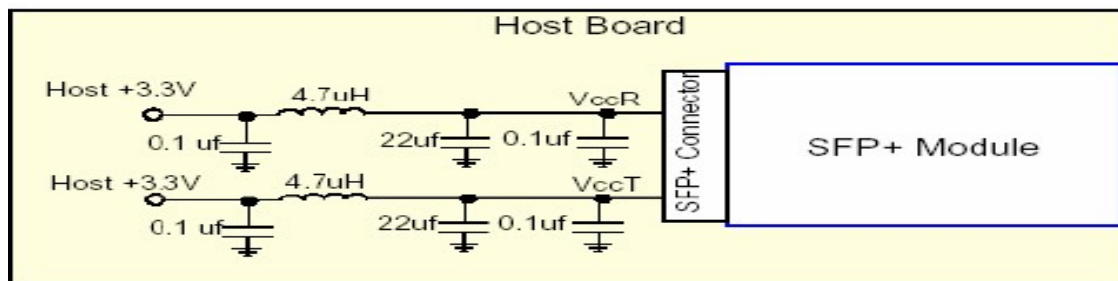

- 8) TD-/+: These are the differential transmitter inputs. They are AC-coupled, differential lines with 100Ω differential termination inside the module. The AC coupling is done inside the module and is thus not required on the host board.

Regulatory Compliance

- Compliant with SFP+ MSA: SFF-8431 Rev4.1
- Compliant with SFF-8472 Rev4.4
- Compliant with IEEE802.3ae
- ESD to the Electrical PINs: compatible with MIL-STD-883E Method 3015.7
- ESD to the Duplex LC Receptacle: compatible with IEC 61000-4-2 GR-1089-CORE
- Immunity compatible with IEC 61000-4-3
- EMI compatible with FCC Part 15 Class B EN55022 Class B (CISPR 22B) VCCI Class B
- Laser Eye Safety compatible with FDA 21CFR 1040.10 and 1040.11 EN60950, EN (IEC) 60825-1,2
- RoHS compliant with 2002/95/EC 4.1&4.2 2005/747/E

Casing overview

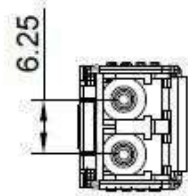
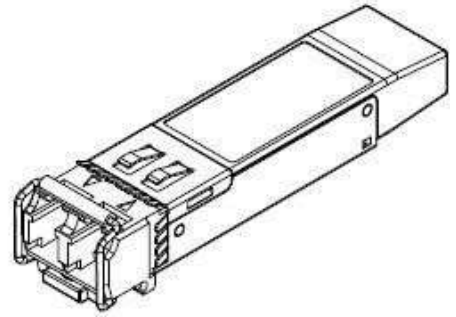
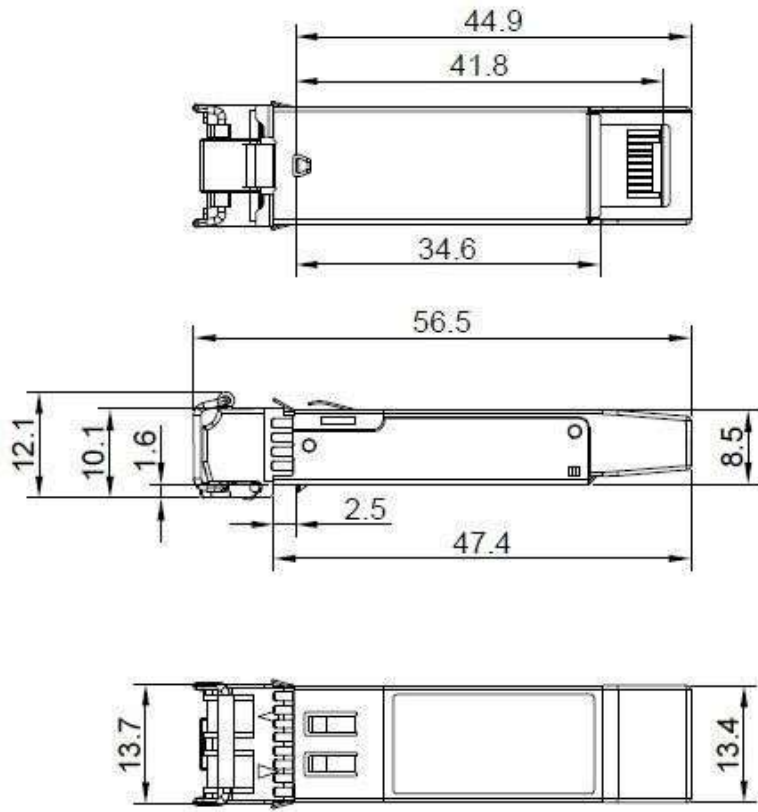

Recommend Circuit Schematic

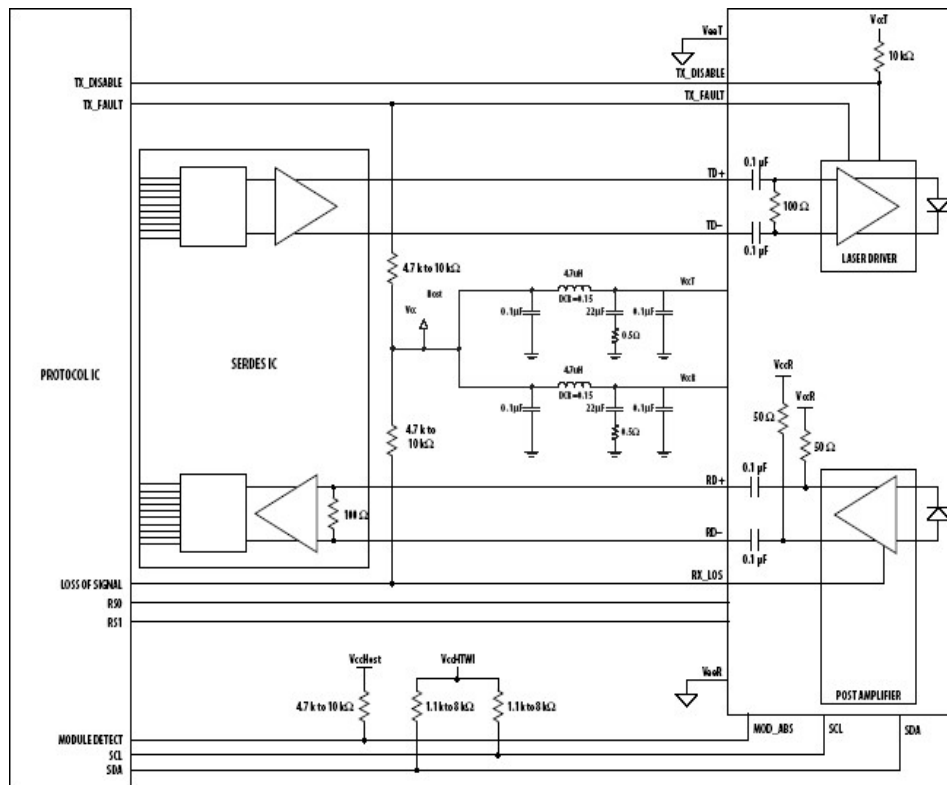

Monitor Specification

The digital diagnostic monitoring interface also defines another 256-byte memory map in EEPROM, which makes use of the 8 bit address 1010001X (A2h). The monitoring specification of this product is described in this table.

Parameter	Range	Accuracy	Calibration
Temperature	-5 to +85°C	±3°C	Internal
Supply Voltage	2.97 to 3.63V	±3%	Internal
Bias Current	3mA to 80mA	±10%	Internal
TX Power	-8.2~0.5dBm	±3dB	Internal
RX Power	-15~0.5dBm	±3dB	Internal

NOTICE:

HD Inc. reserves the right to make changes to or discontinue any optical link product or service identified in this publication, without notice, in order to improve design and/or performance. Applications that are described herein for any of the optical link products are for illustrative purposes only.

HD Inc. makes no representation or warranty that such applications will be suitable for the specified use without further testing or modification.