

SFP-155M-20KM-A

155Mbps SFP Transceiver BIDI 20km Single LC

Product Features

- Up to 155Mbps data links
- 20km with 9/125μm SMF
- 1310nm FP /1550nm FP laser
- Simplex LC Connector
- Hot-pluggable SFP footprint
- Single 3.3V power supply
- Operating temperature: - 0°C to 70°C
- RoHS

Applications

- 155Mbps 100Base-LXRoHS
- 155M Fiber Channel

PART NUMBER	WAVE LENGTH TX/RX	DISTANCE	LASER	TEMPERATUR E
SFP-155M-20KM-A	Tx1310/Rx15 50nm	20km	FP+PIN	COM 0~70°C

1. Product Description

SFP-155M-20KM-A series SFPs are small form factor pluggable (SFP) transceivers compatible with Single-sourcing agreement (MSA). It is suitable for Single-mode fiber (SMF) communications in 155Mbps Ethernet and 155M Fiber Channel.

2. Regulatory Compliance

This transceivers are Class 1 Laser Products comply with FDA regulations. Meet Class 1 eye safety requirements of EN 60825 and the electrical safety requirements of EN 60950.

3. Recommended Operating Conditions

Parameter		Symbol	Min.	Typical	Max.	Unit
SFP-155M-20 KM-A	Operating Case Temperature	T _c	0		70	°C
Power Supply Voltage		V _{cc}	3.15	3.3	3.45	V
Power Supply Current		I _{cc}			300	mA
Data Rate				155		Mbps

4. Optical Characteristics

SFP-155M-20KM-A (Tx1310nm Rx1550nm , 20km Reach)

Parameter	Symbol	Min.	Typical	Max.	Unit
Transmitter					
Centre Wavelength	λ _c	1270	1310	1370	nm
Spectral Width (RMS)	σ			4	nm
Average Output Power	P _{out}	-15		-8	dBm
Extinction Ratio	EX	9			dB
Optical Rise/Fall Time	tr/tf			2	ns
Receiver					
Centre Wavelength	λ _c	1510	1550	1590	nm
Receiver Sensitivity	P _{IN}			-34	dBm
Receiver Overload	P _{MAX}	1			dBm
LOS De-Assert	LOS _D			-35	dBm
LOS Assert	LOS _A	-36			dBm
LOS Hysteresis		0.5		4.5	dB

5. Electrical Characteristics

Parameter	Symbol	Min.	Typical	Max.	Unit
Transmitter					
Input Differential Impedance	Z _{in}	90	100	110	Ω
Data Input Swing Differential	V _{in}	500		2400	mV
Tx-Dis Disable	V _d	2.0		V _{cc}	V
Tx-Dis Enable	V _{en}	0		0.8	V
TX-Fault (Fault)		2.0		V _{cc} +0.3	V

TX-Fault (Normal)		0		0.8	V
Receiver					
Data Output Swing Differential	Vout	370		2000	mV
Rx-Los Fault	Vlf	2.0		Vcc+0.3	V
Rx-Los Normal	Vln	0		0+0.8	V

6. Pin Descriptions

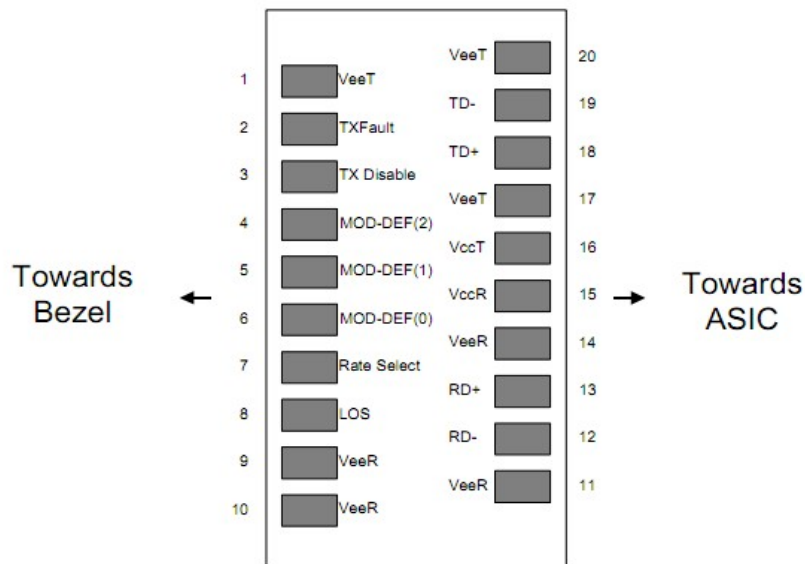

Diagram of Host Board Connector Block Pin Numbers and Names

Pin	Symbol	Description	Ref.
1	VEET	Transmitter Ground (Common with Receiver Ground)	6.1
2	TFAULT	Transmitter Fault. Not supported.	
3	TDIS	Transmitter Disable. Laser output disabled on high or open.	6.2
4	MOD_DEF(2)	Module Definition 2. Data line for Serial ID.	6.3
5	MOD_DEF(1)	Module Definition 1. Clock line for Serial ID.	6.3
6	MOD_DEF(0)	Module Definition 0. Grounded within the module.	6.3
7	Rate Select	No connection required	
8	LOS	Loss of Signal indication. Logic 0 indicates normal	6.4

		operation.	
9	VEER	Receiver Ground (Common with Transmitter Ground)	6.1
10	VEER	Receiver Ground (Common with Transmitter Ground)	6.1
11	VEER	Receiver Ground (Common with Transmitter Ground)	6.1
12	RD-	Receiver Inverted DATA out. AC Coupled.	
13	RD+	Receiver Non-inverted DATA out. AC Coupled.	
14	VEER	Receiver Ground (Common with Transmitter Ground)	6.1
15	VCCR	Receiver Power Supply	
16	VCCT	Transmitter Power Supply	
17	VEET	Transmitter Ground (Common with Receiver Ground)	6.1
18	TD+	Transmitter Non-Inverted DATA in. AC Coupled.	
19	TD-	Transmitter Inverted DATA in. AC Coupled.	
20	VEET	Transmitter Ground (Common with Receiver Ground)	6.1

Notes:

6.1 Circuit ground is internally isolated from chassis ground.

6.2 Laser output disabled on TDIS >2.0V or open, enabled on TDIS <0.8V.

6.3 Should be pulled up with 4.7k - 10kohms on host board to a voltage between 2.0V and 3.6V. MOD_DEF(0) pulls line low to indicate module is plugged in.

6.4 LOS is open collector output. Should be pulled up with 4.7k -10kohms on host board to a voltage between 2.0V and 3.6V. Logic 0 indicates normal operation; logic 1 indicates loss of signal.

7. EEPROM & DDM THRESHOLD

7.1 EEPROM

2 wire address 1010000X (A0hex)

0~95
Serial ID Defined by SFP MSA (96 bytes)
96~127
Vendor Specific (32 bytes)
128~255
Reserved (128 bytes)

EEPROM Serial ID Memory Contents

Addr.	Size (Bytes)	Name of Field	Hex	Description
-------	--------------	---------------	-----	-------------



BASE ID FIELDS				
0	1	Identifier	03	SFP
1	1	Ext. Identifier	04	SFP function is defined by serial ID only
2	1	Connector	01	SC
3-10	8	Transceiver	00 10 02 00 00 00 00 00	Transmitter Code
11	1	Encoding	02	FE
12	1	BR, Nominal	02	155M bps
13	1	Reserved	00	
14	1	Length (9um) km	00	20km
15	1	Length (9um) km	00	
16	1	OM2 Length (50um) m	C8	
17	1	OM1 Length (62.5um) m	C8	
18	1	Length (Copper)	00	
19	1	OM3 Length (50um) m	00	
20-35	16	Vendor Name	48 41 4E 44 41 52 20 20 20 20 20 20 20 20 20 20	HANDAR * OEM available
36	1	Reserved	00	
37-39	3	Vendor OUI	00 00 00	* OEM available
40-55	16	Vendor PN	xx xx xx xx xx xx xx xx xx xx xx xx xx xx xx xx	* OEM available
56-59	4	Vendor Rev	30 31 20 20	01
60-61	2	Wavelength	05 IE/ 06 0E/00 00	1310nm/ 1550nm
62	1	Reserved	00	
63	1	CC_BASE	xx	Check Code for Base ID Field
EXTENDED ID FIELDS				
64-65	2	Options	00 1A	Loss/ TX_Fault/ TX_Disable
66	1	BR, Max	00	
67	1	BR, Min	00	
68-83	16	Vendor SN	43 4C xx xx xx xx xx xx xx xx xx 20 20 20 20 20	SN of Transceiver (ASCII). Exp. "XXXXXXXXXX"
84-91	8	Date Code	xx xx xx xx xx xx 20 20	YY/MM/DD Exp. 160727
92	1	Diagnostic Monitoring	6B	
93	1	Enhanced Options	90	
94	1	SFF_8472	01	



		Compliance		
95	1	CC_EXT	checksum	Checksum for Extended ID
VENDOR SPECIFIC ID FIELDS				
96-127	32	Vendor Specific	20 20 20.....	Depends on Customer Info
128-255	128	Reserved	FF FF FF.....	Depends on Customer Info

7.2 DDM THRESHOLD

/D	Low Alarm	Low Warn	High Warn	High Alarm
Temp	-10°C	-5°C	75°C	80°C
Voltage	2.97V	3.13V	3.47V	3.63V
Tx Bias	5mA	10mA	60mA	65mA
Tx Power	-18dBm	-16dBm	-7dBm	-5dBm
Rx Power	-36dBm	-34dBm	-1dBm	1dBm

8. Recommend Circuit

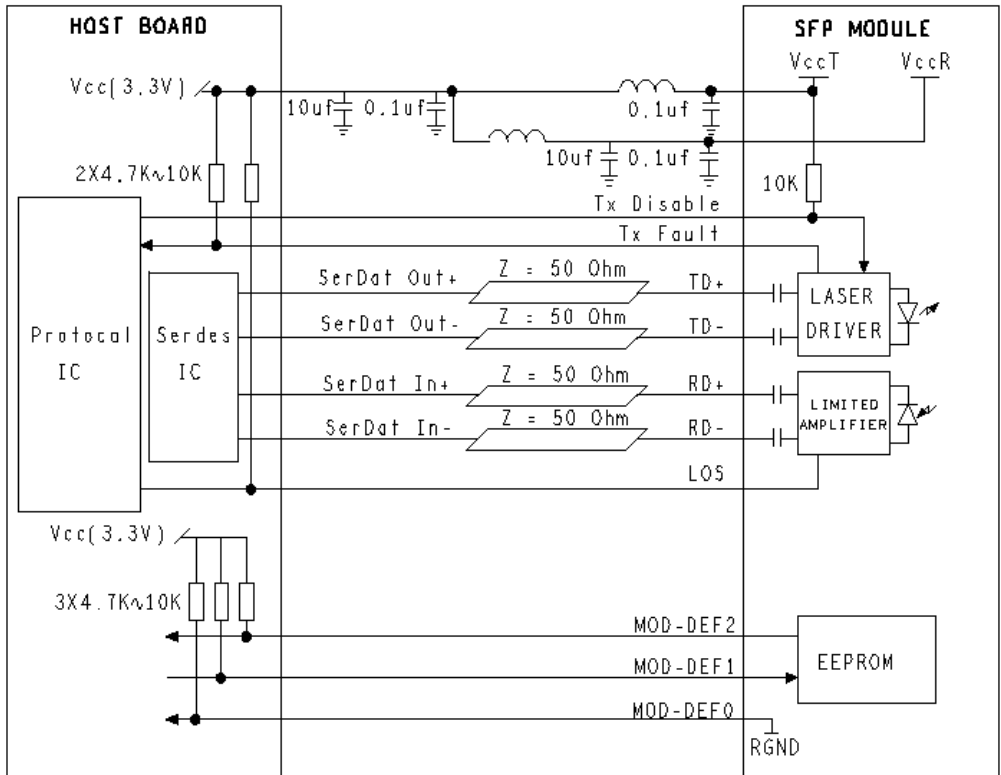

9. Mechanical Specifications

